

LINEAR QUADRATIC GAUSSIAN CONTROL FOR UPFC AUXILIARY STABILIZER

Mojtaba Shirvani¹, Reza Sharifian Dastjerdi², Ramtin Sadeghi³, Payam Ghaebi Panah⁴

^{1,2,3,4}Department of Electrical Engineering, Majlesi Branch, Islamic Azad University, Isfahan, Iran
shirvani@iaumajlesi.ac.ir, sharifian@iaumajlesi.ac.ir, sadeghi@iaumajlesi.ac.ir, ghaebipanah@iaumajlesi.ac.ir

ABSTRACT: *Linear quadratic Gaussian (LQG) control is a powerful and accurate method to design controllers in the electric power systems. This paper aims at designing unified power flow controller (UPFC) auxiliary stabilizer by using LQG control strategy. The proposed method is simulated based on a multi machine electric power system. The effectiveness and validity of the proposed method is evaluated under several operating conditions and uncertainties.*

KEYWORDS: Linear Quadratic Gaussian Control, Unified Power Flow Controller, Stability, Uncertainty.

I. INTRODUCTION

Linear-quadratic-Gaussian (LQG) control is a linear-quadratic estimator (LQE) with a linear-quadratic regulator (LQR). The separation principle guarantees that these can be designed and computed independently. LQG control applies to both linear time-invariant systems as well as linear time-varying systems. The application to linear time-invariant systems is well known. The application to linear time-varying systems enables the design of linear feedback controllers for non-linear uncertain systems. LQG control has been widely used in electric power systems.

Paper [1] presents the application of the Linear Quadratic Gaussian (LQG) controller for voltage and frequency regulation of an isolated hybrid wind-diesel scheme. The scheme essentially consists of a vertical axis wind turbine driving a self-excited induction generator connected via an asynchronous (AC-DC-AC) link to a synchronous generator driven by a diesel engine. The synchronous generator is equipped with a voltage regulator and a static exciter. The wind generator and the synchronous generator together cater for the local load and power requirement. However, the load bus voltage and frequency are governed by the synchronous generator. The control objective aims to regulate the load voltage and frequency. This is accomplished via controlling the field voltage and rotational speed of the synchronous generator. The complete nonlinear dynamic model of the system has been described and linearized around an operating point. The standard Kalman filter technique has been employed to estimate the full states of the system. The computational burden has been minimized to a great extent by computing the optimal state feedback gains and the Kalman state space model off-line. The proposed controller has the advantages of robustness, fast response and good performance. The hybrid wind diesel energy scheme with the proposed controller has been tested through a step change in both wind speed and load impedance. Simulation results show that accurate tracking performance of the proposed hybrid wind diesel energy system has been achieved.

On the other hand, UPFC has been widely used in electric power systems [2-6]. Paper [6] discusses that the generalized unified power flow controller (GUPFC) is one of the most versatile flexible ac transmission system (FACTS) controllers which controls the active and reactive power flows in multiple transmission lines originating from a

substation while controlling the sending end bus voltage. The sending end bus voltage is regulated by control of shunt reactive current while the active and reactive power flows in the transmission line are regulated by series injected voltages. This paper reports the analysis and study of subsynchronous resonance (SSR) characteristics of hybrid compensated system with GUPFC. The various operating mode combinations of series and shunt converters are considered to investigate their effect on SSR characteristics. The methods of analysis of SSR with GUPFC is based on the evaluation of damping torque, eigenvalues of the system and transient simulation. The computation of damping torque considers D-Q model of GUPFC to determine the torsional mode stability. The study is performed on a system adapted from IEEE Second Benchmark Model (SBM). The results demonstrate the effectiveness of series real injected voltage in mitigating the SSR. Paper [5] develops new control approaches for both series and shunt inverters of UPFC. The proposed controller algorithms of shunt and series inverters are based on fuzzy logic controller and rotating orthogonal-coordinate method, respectively. Dynamic control of power flow using proposed UPFC is analyzed as mathematically. Power System Computer-Aided Design (PSCAD) is used to simulate the system and test UPFC in the simulation environment. The test results are presented to show the increased stability of the system and improved dynamic response of UPFC during faults occurred in the transmission line.

This paper aims at designing unified power flow controller (UPFC) auxiliary stabilizer by using LQG control methodology. The proposed method is simulated based on a multi machine electric power system. The effectiveness and validity of the proposed method is evaluated under several operating conditions and uncertainties.

II. LINEAR QUADRATIC GAUSSIAN CONTROL

The LQG problem can be formulated as follow. Consider the linear dynamic system,

$$\dot{\mathbf{X}}(t) = \mathbf{A}(t)\mathbf{X}(t) + \mathbf{B}(t)\mathbf{u}(t) + \mathbf{v}(t) \quad (1)$$

$$\mathbf{y}(t) = \mathbf{C}(t)\mathbf{X}(t) + \mathbf{W}(t) \quad (2)$$

Where \mathbf{X} represents the vector of state variables of the system, \mathbf{u} the vector of control inputs and \mathbf{y} the vector of measured outputs available for feedback. Both additive white Gaussian system noise $\mathbf{v}(t)$ and additive white Gaussian measurement noise $\mathbf{w}(t)$ affect the system. Given

this system, the objective is to find the control input history $u(t)$ which at every time t may depend only on the past measurements $y(t)$, $0 \leq t < T$ such that the following cost function is minimized,

$$J = E(x^T(T)Fx(T) + \int_0^T x^T(t)Q(t)x(t) + u^T(t)R(t)u(t)dt) \quad (3)$$

$F \geq 0 \quad Q(t) \geq 0 \quad R(t) > 0$

where E denotes the expected value. The final time (horizon) T may be either finite or infinite. If the horizon tends to infinity the first term $x^T(T)Fx(T)$ of the cost function becomes negligible and irrelevant to the problem. In addition, to keep the costs finite the cost function has to be taken to be J/T .

The LQG controller that solves the LQG control problem is specified by the following equations,

$$\dot{\hat{x}} = A(t)\hat{x}(t) + B(t)u(t) + K(t)(y(t) - C(t)\hat{x}(t)) \quad \hat{x}(0) = E(x(0)) \quad (4)$$

$$u(t) = -L(t)\hat{x}(t) \quad (5)$$

The matrix $K(t)$ is called the Kalman gain of the associated Kalman filter represented by the first equation. At each time t this filter generates estimates $\hat{x}(t)$ of the state $x(t)$ using the past measurements and inputs. The Kalman gain $K(t)$ is computed from the matrices $A(t)$, $C(t)$, the two intensity matrices $V(t)$, $W(t)$ associated to the white Gaussian noises $V(t)$ and $W(t)$ and finally $E(x(0))$, $x^T(0)$. These five matrices determine the Kalman gain through the following associated matrix Riccati differential equation,

$$\dot{P}(t) = A(t)P(t) + P(t)A^T(t) - P(t)C^T(t)W^{-1}(t)C(t)P(t) + V(t) \quad (6)$$

$$P(0) = E(x(0)x^T(0)) \quad (7)$$

Given the solution $P(t)$, $0 \leq t \leq T$ the Kalman gain equals,

$$K(t) = P(t)C^T(t)W^{-1}(t) \quad (8)$$

The matrix $L(t)$ is called the feedback gain matrix. This matrix is determined by the matrices $A(t)$, $B(t)$, $Q(t)$, $R(t)$

and F through the following associated matrix Riccati differential equation,

$$-\dot{S}(t) = A^T(t)S(t) + S(t)A(t) - S(t)B(t)R^{-1}(t)B^T(t)S(t) + Q(t) \quad (9)$$

$$S(T) = F \quad (10)$$

Given the solution $S(t)$, $0 \leq t \leq T$ the feedback gain equals,

$$L(t) = R^{-1}(t)B^T(t)S(t) \quad (11)$$

Observe the similarity of the two matrix Riccati differential equations, the first one running forward in time, the second one running backward in time. This similarity is called duality. The first matrix Riccati differential equation solves the linear-quadratic estimation problem (LQE). The second matrix Riccati differential equation solves the linear-quadratic regulator problem (LQR). These problems are dual and together they solve the linear-quadratic-Gaussian control problem (LQG). Therefore, the LQG problem separates into the LQE and LQR problem that can be solved independently. Therefore, the LQG problem is called separable. When $A(t)$, $B(t)$, $C(t)$, $Q(t)$, $R(t)$ and the noise intensity matrices $V(t)$, $W(t)$ do not depend on t and when T tends to infinity the LQG controller becomes a time-invariant dynamic system. In that case both matrix Riccati differential equations may be replaced by the two associated algebraic Riccati equations.

III. TEST SYSTEM

A two-area, four-machine power system installed with UPFC is considered as case study. Figure 1 shows the single line diagram of the system. The system data are taken from [7]. In order to evaluation of uncertainties, three loading conditions are considered as heavy, nominal and light as listed in Table 1.

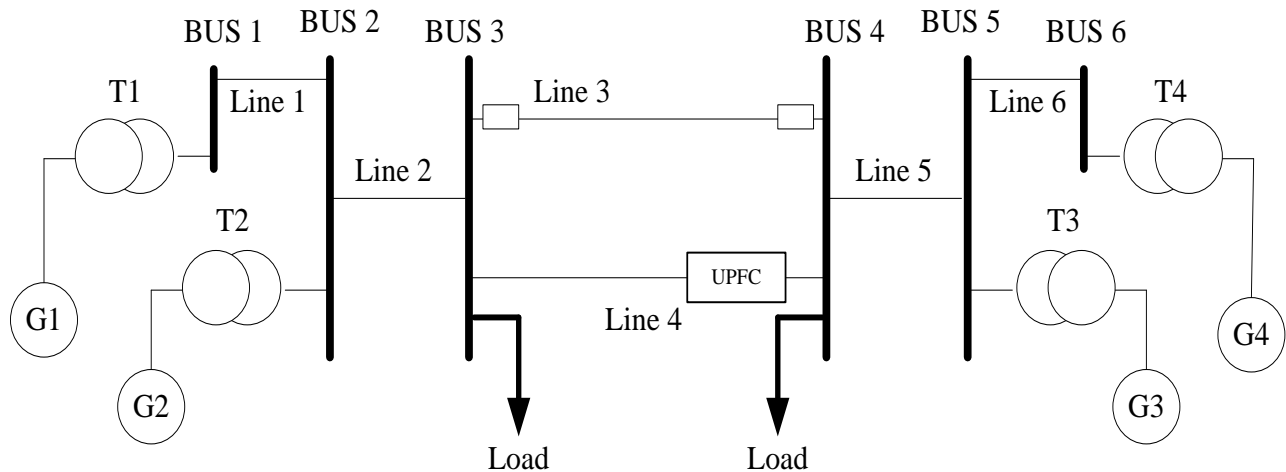

Figure 1: The single-line diagram of two-area four-machine power system

Table 1: The loading conditions

Light loading	Nominal loading	Heavy loading
20% decreasing load	Nominal load	20% increasing load

The nonlinear dynamic model of the system installed with UPFC is given as (12). The dynamic model of the system is completely presented in [7] and also dynamic model of the system installed with UPFC is presented in [7].

$$\begin{cases} \dot{\omega}_i = \frac{(P_m - P_e - D\omega)}{M} \\ \dot{\delta}_i = \omega_0(\omega - 1) \\ E'_{qi} = \frac{(-E_q + E_{fd})}{T'_{do}} \\ \dot{E}_{fdi} = \frac{-E_{fd} + K_a(V_{ref} - V_t)}{T_a} \\ \dot{V}_{dc} = \frac{3m_E}{4C_{dc}}(\sin(\delta_E)_{Ed} + \cos(\delta_E)_{Eq}) + \\ \frac{3m_B}{4C_{dc}}(\sin(\delta_B)_{Bd} + \cos(\delta_B)_{Bq}) \end{cases}$$

Where, i: generators number; δ : rotor angle; ω : rotor speed; P_m : mechanical input power; P_e : electrical output power; E_q : internal voltage behind x_d ; E_{fd} : equivalent excitation voltage; T_e : electric torque; T'_{do} : time constant of excitation circuit; K_a : regulator gain; T_a : regulator time constant; V_{ref} : reference voltage; V_t : terminal voltage; m_B : pulse width modulation of series inverter; δ_B : phase angle of series injected voltage; m_E : pulse width modulation of shunt inverter; δ_E : phase angle of the shunt inverter voltage.

IV. SIMULATION RESULTS

As stated before, LQG control is used to design an auxiliary stabilizer based on the UPFC in the proposed test system given in section 3. The simulation results after installing stabilizer are presented here. Figures 2 to 6 show the simulation results following disconnection of line 3 at second 1. Figure 2 shows the speed of generator 1 following disturbance. It is clear that the oscillations are damped out and the system becomes stable after almost 15 seconds. Figure 3 shows the speed of generator 2 following disturbance. This response is similar to the Figure 2, since generators 1 and 2 are placed at one area, and their oscillations will be similar. Figure 4 shows the speed of generator 3 and it is clear that, this generator suffers different oscillations than the generators in the other area. The buses at two-ends of the disconnected line are also useful to study. In this regard, Figures 5 and 6 show the voltages at buses 3 and 4 following disturbance. The oscillations are seen in these figures as well as it is clear that the system is stable following disturbance.

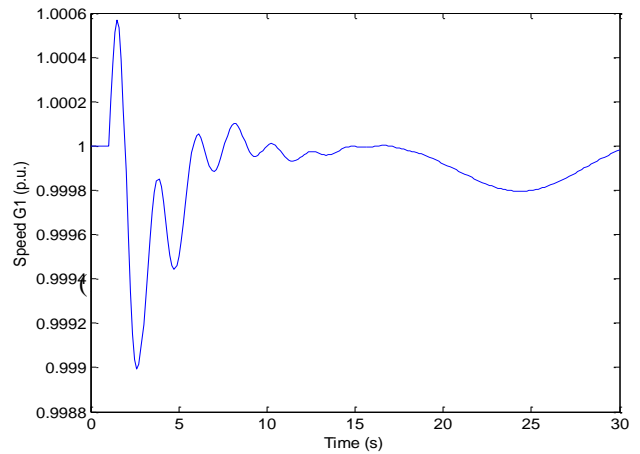

Figure 2: Speed of generator 1 following disturbance at nominal operating condition

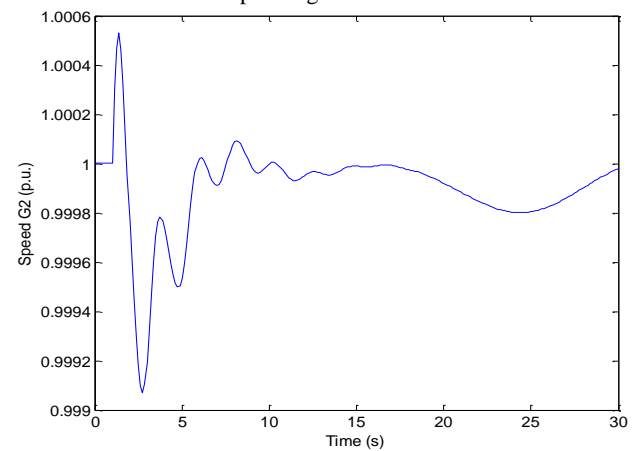

Figure 3: Speed of generator 2 following disturbance at light operating condition

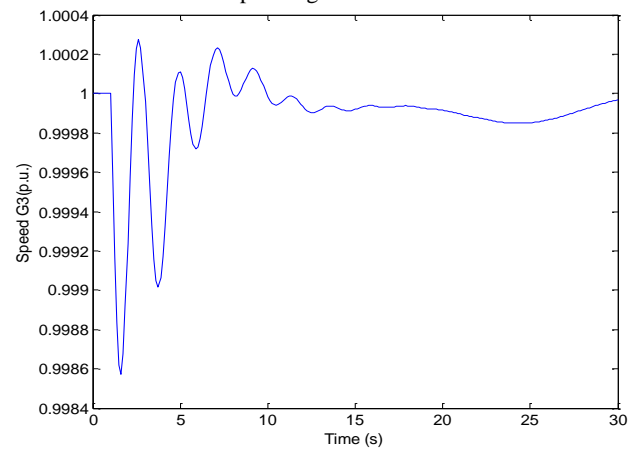

Figure 4: Speed of generator 3 following disturbance at heavy operating condition

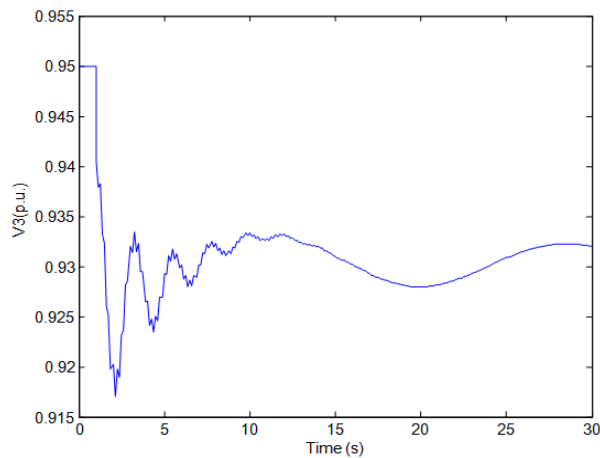

Figure 5: Voltage of bus 3 following disturbance at nominal operating condition

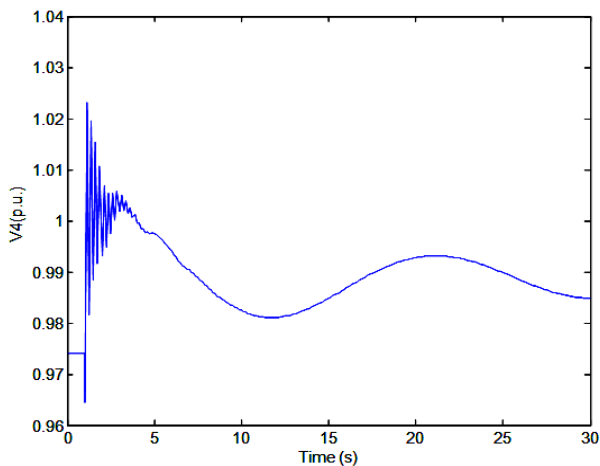

Figure 6: Voltage of bus 4 following disturbance at heavy operating condition

V. CONCLUSIONS

This paper addressed an auxiliary stabilizer by using LQG control based on the unified power flow controller (UPFC). The proposed method was simulated at a two-area four-machine electric power system. The effectiveness and validity of the proposed method was evaluated under several simulations.

REFERENCES

- [1] Kassem A.M., and Yousef A.M., "Robust control of an isolated hybrid wind–diesel power system using Linear Quadratic Gaussian approach," *International Journal of Electrical Power & Energy Systems*, **33**(4): 1092-1100 (2011).
- [2] Khoshkbar Sadigh A., Tarafdar Hagh M., and Sabahi M., "Unified power flow controller based on two shunt converters and a series capacitor," *Electric Power Systems Research*, **80**(12): 1511-1519(2010).
- [3] Vural A.M., and Tümay M., "Mathematical modeling and analysis of a unified power flow controller: A comparison of two approaches in power flow studies and effects of UPFC location," *International Journal of Electrical Power & Energy Systems*, **29**(8): 617-629(2007).
- [4] Ahmad S., Albatsh F.M., Mekhilef S. et al., "Fuzzy based controller for dynamic Unified Power Flow Controller to enhance power transfer capability," *Energy Conversion and Management*, **79**: 652-665(2014).
- [5] Saribulut L., Teke A., and Tümay M., "Dynamic control of unified power flow controller under unbalanced network conditions," *Simulation Modelling Practice and Theory*, **19**(2): 817-836 (2011).
- [6] Thirumalaivasan R., Prabhu N., Janaki M. et al., "Analysis of subsynchronous resonance with generalized unified power flow controller," *International Journal of Electrical Power & Energy Systems*, **53**: 623-631(2013).
- [7] Kundur P., *Power system stability and control*: Tata McGraw-Hill Education, 1994.